

Vertical inline pump

Operating Conditions

- Vertical shaft
- Axial load
- Big temperature difference between inner & outer rings.

Bearing Requirements

- Sealing performance
- Low noise

Bearing Selection

- Double Row Angular Contact Ball Bearings
- Deep Groove Ball Bearings with seals

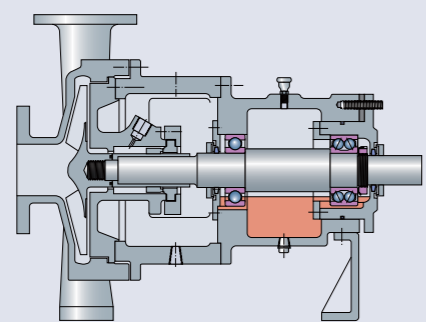

Process Pump

Operating Conditions

- Radial & axial load
- Speed range 1000~3000rpm

Bearing Requirements

- Long service life under high radial & axial load
- Small axial clearance

Bearing Selection

- Cylindrical Roller Bearings
- Double Row Angular Contact Ball Bearings
- Deep Groove Ball Bearings with seals
- Tapered Roller Bearings

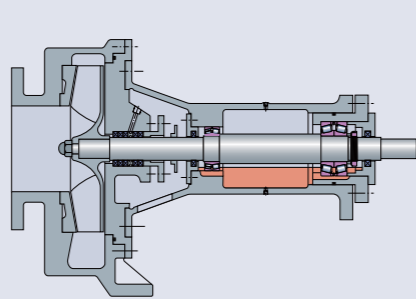

Slurry Pump

Operating Conditions

- Heavy radial and axial load
- Impact load
- Speed: 800~2000rpm

Bearing Requirements

- Small axial clearance
- Long life under high load

Bearing Selection

- Cylindrical Roller Bearings
- Double Row Tapered Roller Bearings
- Spherical Roller Bearings
- Thrust Spherical Roller Bearings

www.ubc-bearing.com



QR code to visit UBC website

Bearing Solutions for Screw Compressor and Centrifugal Pump

www.ubc-bearing.com

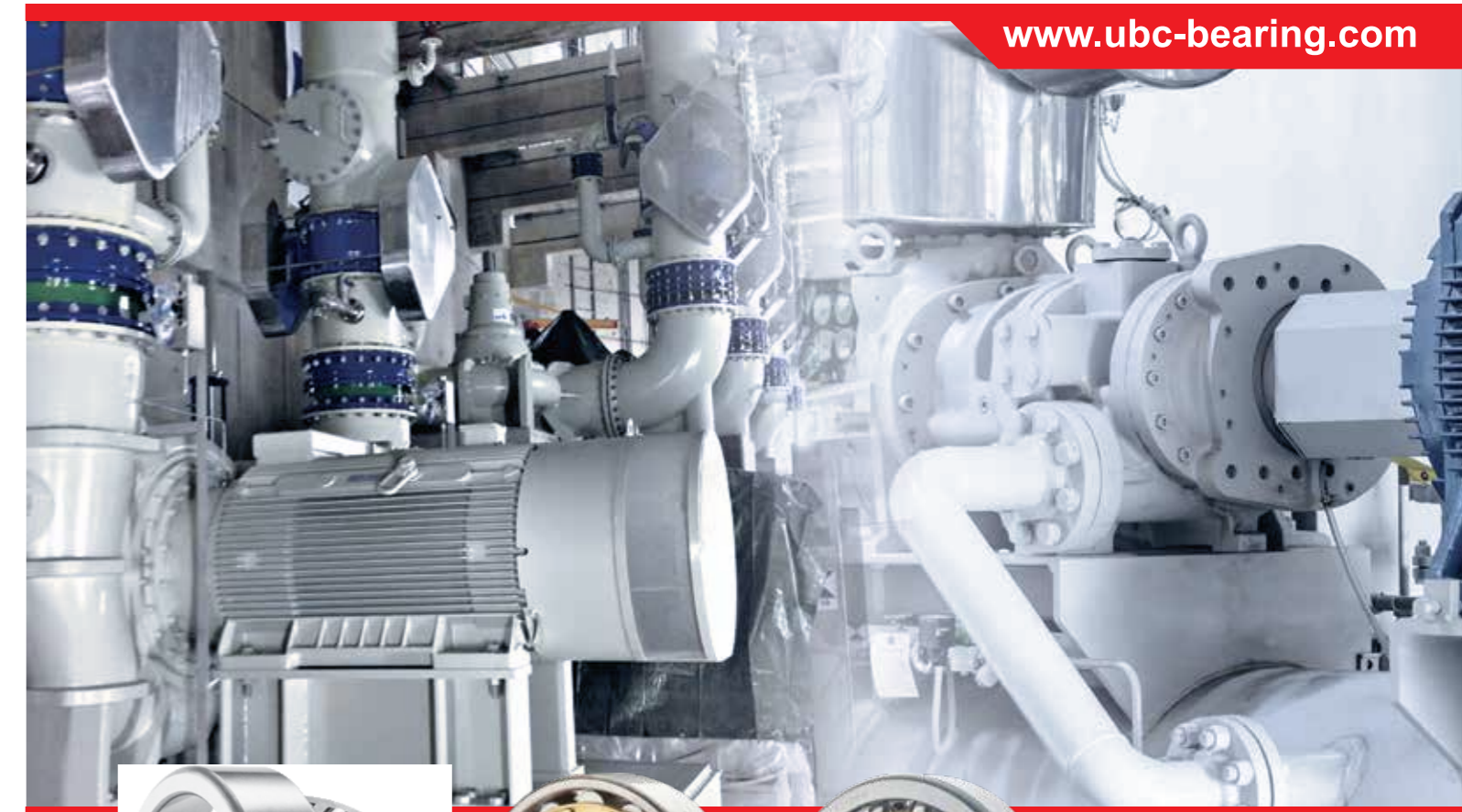

Deep Groove Ball Bearing

- Low noise (superior to Z2V1) due to fine finished raceways and high quality balls.
- Optimized internal designs enabled higher radial and axial load capacity, suitable for small and medium duty centrifugal pumps.
- Bearing with special material available for chemical applications.



Cylindrical Roller Bearing

- High radial load capacity with high speed.
- Optimized rib design result in less friction and better lubrication.
- Logarithmic curve designed raceways and roller profile minimize stress concentrations.



Double Row Angular Contact Ball Bearing

- Compact structure for small mounting envelop.
- Interchangeable with two pieces of single row angular contact ball bearings arranged in back-to-back arrangement.
- Crown cage design provides better ball guidance and lubrication, which resulting in a higher speed rating and reduced noise.
- 30 ° (with suffix A) contact angle available, which can accommodate combined radial and axial loads from double directions.



Single Row Tapered Roller Bearing

- Deep contact angle, mounted in pairs to support combined radial and axial loads.
- Optimized rib design enable to support approximately 1.5 times higher axial load than normal.
- Logarithmic curve designed raceways and roller profile minimize stress concentrations.



Spherical Roller Bearing

- High radial and axial load capability and ability to operate in misaligned conditions.
- E series with enhanced internal structure accommodate more and larger rollers enabling to withstand heavier load than conventional type.
- Optimized internal geometry and rolling contact surface benefit less friction.
- Optimized cages provide better rolling guidance.



Double Row Tapered Roller Bearing

- Equivalent to a pair of single row tapered roller bearing in DF arrangement with fixed internal clearance easy for mounting.
- High radial load and axial load on both directions.



An **IKO** Company

UBC Precision Bearing Mfg. Co.,Ltd.

Suite 1703, Zhongrong Plaza, 1088 South Pudong Road, Pudong New District, Shanghai
 TEL: +86-21-64904536
 FAX: +86-21-68781355
 Email: export@ubc-bearing.com

China factory and Technology Center

UBC (Suzhou) Bearing Co.,Ltd.

1083 Southeast Avenue, Changshu National New & Hi-tech Industrial Development Zone, Changshu City, Jiangsu Province, China



An **IKO** Company

Our Bearings, Your Solutions



Bearing Solutions For Screw Compressor

Compressors are one of the most common mechanical equipment that widely used in each industry and household applications, such as food and beverage industry, chemical, mechanical manufacturing, automation and chillers, etc. Since it plays important roles in providing power and heat exchanger, the efficiency of compressor means great in energy saving.

Through years of research and development in bearing industry, and cooperation with many famous compressor manufacturers, UBC has developed series of products with advanced optimizations in internal designs and manufacturing technology, which resulting in raising the bar on service life, higher load ratings, smooth running and energy saving.

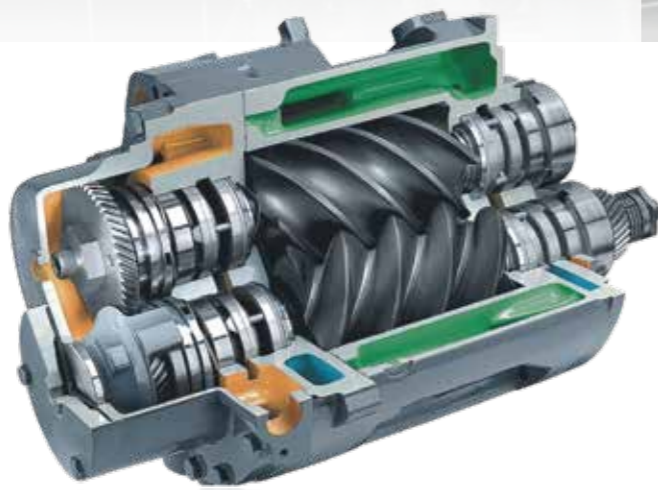

Screw Compressor Bearing Loads

Bearing load in twin screw compressors is produced by:

- Gas pressure on the rotors
- Gear forces from input and timing gears
- Rotor forces from transmission of torque from one to the other
- Induced loads from centrifugal forces in thrust bearings
- Spring preload or balance piston forces
- Loads from belts drive

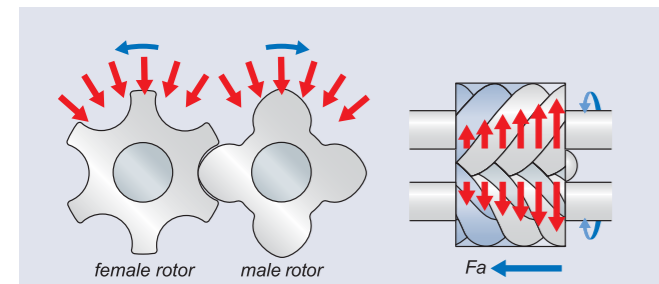

The gas pressure is low at the suction side and higher at the discharge side. The gas pressure along the length of rotor produces radial forces and axial forces from the pressure acting on the projected areas. The net axial force always towards to the suction side.

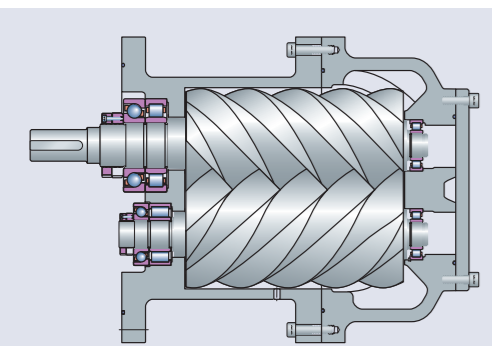

Oil Injected Screw

Operating Conditions

- Medium speed
- Large axial & radial loads
- Oil circulation

Bearing Requirements

- Specific axial & radial clearances to provide precise screw guidance
- Plastic cage compatibility with special oils
- High speed capacity

Bearing Selection

- Cylindrical Roller Bearings
- Tapered Roller Bearings
- Deep Groove Ball Bearings
- Angular Contact Ball Bearings with 40° contact angle

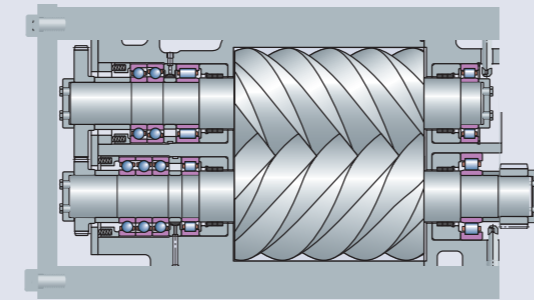

Oil Free Screw Compressor

Operating Conditions

- High speed (7000-25000r/min)
- Moderate axial & radial loads
- Oil jet lubrication

Bearing Requirements

- Specific axial & radial clearances to provide precise screw guidance
- High speed performance
- Heat resistance

Bearing Selection

- Cylindrical Roller Bearings – with outer ring guided brass cage, P6 or P5 accuracy
- Angular Contact Ball Bearings – with outer ring guided brass cage, 15° and 25° contact angle, P6 or P5 accuracy
- 4-point contact ball bearings – with outer ring guided brass cage, P6 accuracy, reduced axial clearance

Bearing Solutions for Screw Compressor



Tapered Roller Bearing

- Optimized rib design contribute to smooth running and approximately 1.5 times of axial load capacity than traditional design.
- Convex curve designed raceways and roller profile minimize stress concentrations.
- Higher precision manufacturing standards utilized (P5- running accuracy).



Deep Groove Ball Bearing

- Typically with C3 clearance and work as the reverse bearing.
- High axial positioning accuracy with P5 running accuracy.
- Vibration level better than Z2V1 as conventional supply.
- Steel and polyamide cage available to accommodate demands of various applications.



Angular Contact Ball Bearing

- P5 running accuracy provide high positioning accuracy.
- Increased load capacity with high speed.
- Universally matchable design, various configurations are available either in single or pair.
- Outer ring guided brass cage or high performance polymer cages available.

Single Row Cylindrical Roller Bearing

- Restricted and interchangeable clearance for high radial locating accuracy.
- P5 running accuracy as standard.
- Optimized internal design with logarithmic roller curve.
- Brass cage or high performance polymer cages available.

Four Point Contact Ball Bearing

- Primarily used in oil flooded refrigeration and high speed dry air compressors to support axial load only.
- C2 clearance for compressor application.
- More and larger balls incorporated to support high axial load.
- Outer ring guided machined brass or polymer cage well suited for high speed.



Bearing Solutions for Centrifugal Pump

The centrifugal pump is a type of pump that uses the kinetic energy of a rotating impeller to impart motion to the fluid. The rotating impeller accelerate the fluid through its vanes and into the pump casing where the kinetic energy of the moving fluid is converted to potential energy at higher pressure, as the fluid leaves the impeller through the pump discharge, more fluid is drawn into the pump inlet where the pressure is the lowest. This fluid passes through the impeller as still more fluid enters the impeller.

Depending on the media it conveyed, the centrifugal pump includes water pump, chemical and gas pump, and slurry pump.

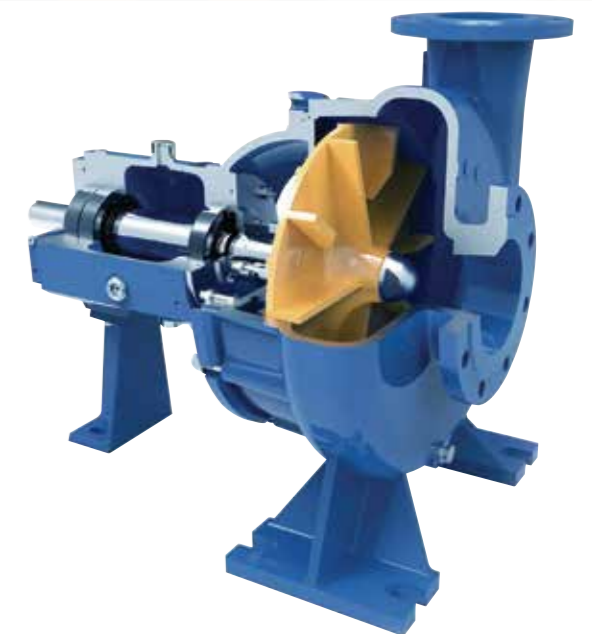

Pump Bearing Loads

The pump bearings support the hydraulic loads imposed on the impeller, the mass of the impeller and shaft, and the loads due to the shaft coupling or belt drive. The hydraulic loads comprise of hydrostatic and momentum forces from the fluid. The forces on the impeller are simplified into two components: axial load and radial load.

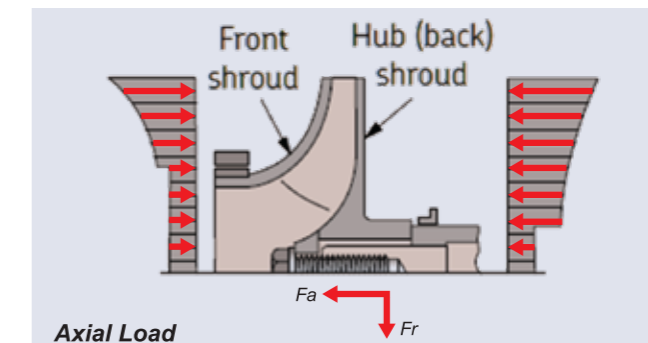

Axial Load

The axial hydraulic pressures acting on a single stage centrifugal pump are illustrated in the figure. The axial load is equal to the sum of the forces.