



Bearing Solutions For Power Transmission

In almost every industrial process, available in every possible shape and size, gear units and drivelines face an extremely wide range of operating requirements and conditions. But regardless of industry or application, all industrial transmissions share a common set of challenges – they must perform as reliably, efficiently and cost-effectively as possible.

As a result of the numerous projects that have been developed in close collaboration with reducer manufacturers, UBC has acquired sound field experience and perfect knowledge technically and economically in this sector. Our speciality enables us to propose optimized solutions for each kind of reducers that operated in every applications.

- Increase load capacity
- Improve transmission efficiency
- Decrease noise level
- Decrease heat generation
- Improve operational reliability

UBC Typical Products

CRB and TRB with enhanced design are typical products of UBC. UBC's achieved advantages in power transmission compared with other product in the market is that our continuous innovation in design, manufacturing and critical quality criterion on material selection and heat treatment.

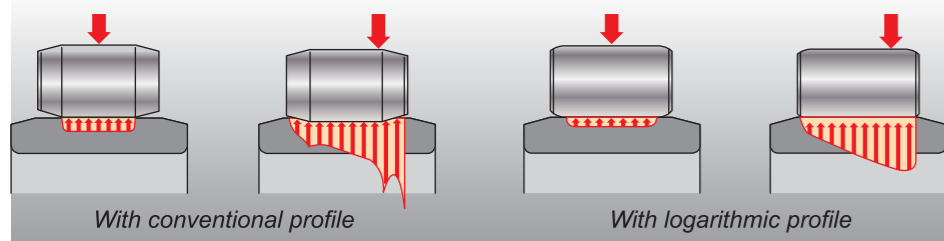

► Optimum Design

Improved curves of rolling elements and raceways with logarithmic profile to distribute loads evenly along the rollers. This optimization contributes to prevent stress peaks at the roller ends and reduce sensitivity to misalignment.



► Heat treatment

High quality level bearing steel with advanced heat treatment technology, improves the reliability fundamentally.

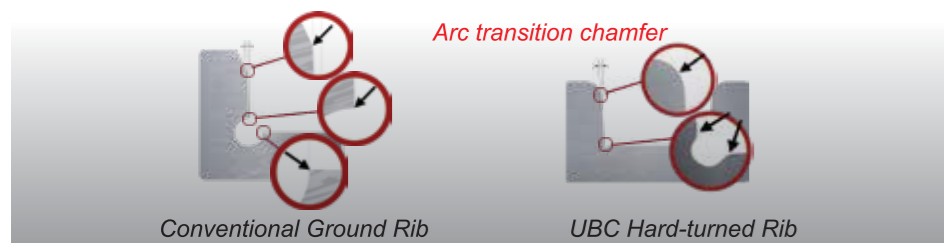

► Innovative Manufacturing

CNC hard-turned ribs instead of grinding, fine profile contribute to better roller guide, low friction and better lubrication ingress. The axial load capacity is approximately 1.5 times higher than conventional method.



Parallel & Helical Industrial Gear Units

Parallel and helical gear units are designed for tough applications such as mining conveyors, paper mills, extruders, continuous casters or harbour cranes. They must provide high operational reliability in harsh conditions such as hot, humid and dusty environments, at very low speed and with heavy loads. The challenge for bearings used in it is compact structure with increased load capacity, low friction, low noise and high reliability.

UBC products have the capabilities to meet these OEM customers' demands by applying a system approach to achieve feasible modular production with improved performance.



Roller Bearings in Gearbox

► Cylindrical Roller Bearing



Cylindrical roller bearings are generally recommended for non-locating bearing positions, due to the internal geometry, the bearings are suitable to operate at high speed with high load capacity. UBC cylindrical roller bearing has optimized component geometry, which enabled the bearings to withstand heavy load even in the event of slight misalignment.

► Deep Groove Ball Bearing



Deep groove ball bearings are usually used in small gearbox to support radial load as well as a certain of axial load. The bearings are lubricated with oil and can operate at very high speed. Designs with full complement designs are also available.



► Tapered Roller Bearing



Tapered roller bearings are used as location bearing, such as drive pinions, to withstand radial load and axial load generated from the helical gear. Special variants of tapered roller bearings help to maintain the accuracy of the end play or preload, enhancing the performance of the gear mesh. UBC TRB has optimized roller and raceway profile, which enabled the bearing to withstand very high loads with improved load distribution. The turned rib profile enable the bearing to withstand approximately 1.5 times axial load than conventional type.

► Spherical Roller Bearing

Spherical roller bearings are multiple in designs and has numerous benefits. The bearings offer excellent performance at high speed with high radial and axial load capacity and self-aligning ability. They can be used as a locating or non-locating or floating bearing and can be incorporated in any gearbox design.

Planetary Gearbox

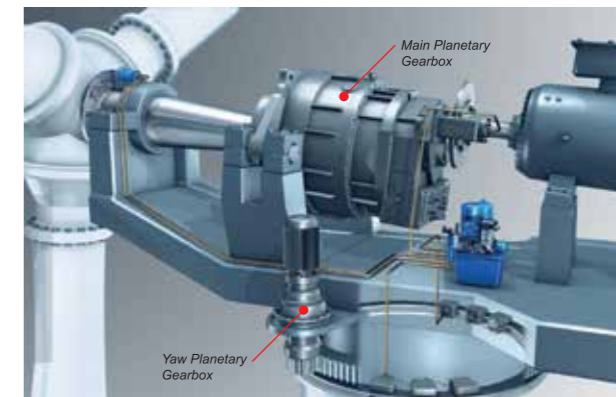

► Single Row Cylindrical Roller Bearings, Full Complement

Cageless full complement design has maximum load capacity compared to same size with cages. NCF design with black oxide coating is available in UBC cylindrical roller bearing series.

Bearing Location: Planetary Carrier



► Single Row Tapered Roller Bearing

Single row tapered roller bearing features to support high radial and axial load in one direction. UBC tapered roller bearings are available in both metric and inch sizes with optimized roller, raceway and rib designs, and capable of taking higher loads.

Bearing Location: Planetary Carrier



► Single Row Cylindrical Roller Bearing With Cage

UBC single row cylindrical roller bearings have optimized internal designs, features with high rigidity, increased load capacity, higher speed ratings and quiet in operation.

Bearing Location: High-Speed Intermediate Shaft



► Full Complement Cylindrical Roller Bearings, Without Outer Ring

The raceway of this bearing is integrated in the planetary gear, which is prevalent in planetary gear solutions with high load capacity and low section height. UBC bearings for planetary gear are available with single row and double row designs.

Bearing Location: Planetary Gear



► Double Row Tapered Roller Bearing

Double row tapered roller bearing has a double-raceway inner ring with roller and cage assembly and two outer rings with a spacer. The bearing features compact design with high rigidity and can withstand radial load and axial load from both directions. The bearing clearance is pre-fixed for easier mounting.

Bearing Location: High-Speed Intermediate Shaft
High-Speed Shaft
Low-Speed Intermediate Shaft



► Four-Point Contact Ball Bearing

Four-point contact ball bearings are designed with 35° contact angle and two axial split inner rings. The bearings are usually used as axial location bearings in the configurations to accommodate pure axial loads from both directions or combined loads.

Bearing Location: High-Speed Intermediate Shaft
High-Speed Shaft

www.ubc-bearing.com



QR code to visit UBC website

Bearing Solutions for Power Transmission

www.ubc-bearing.com

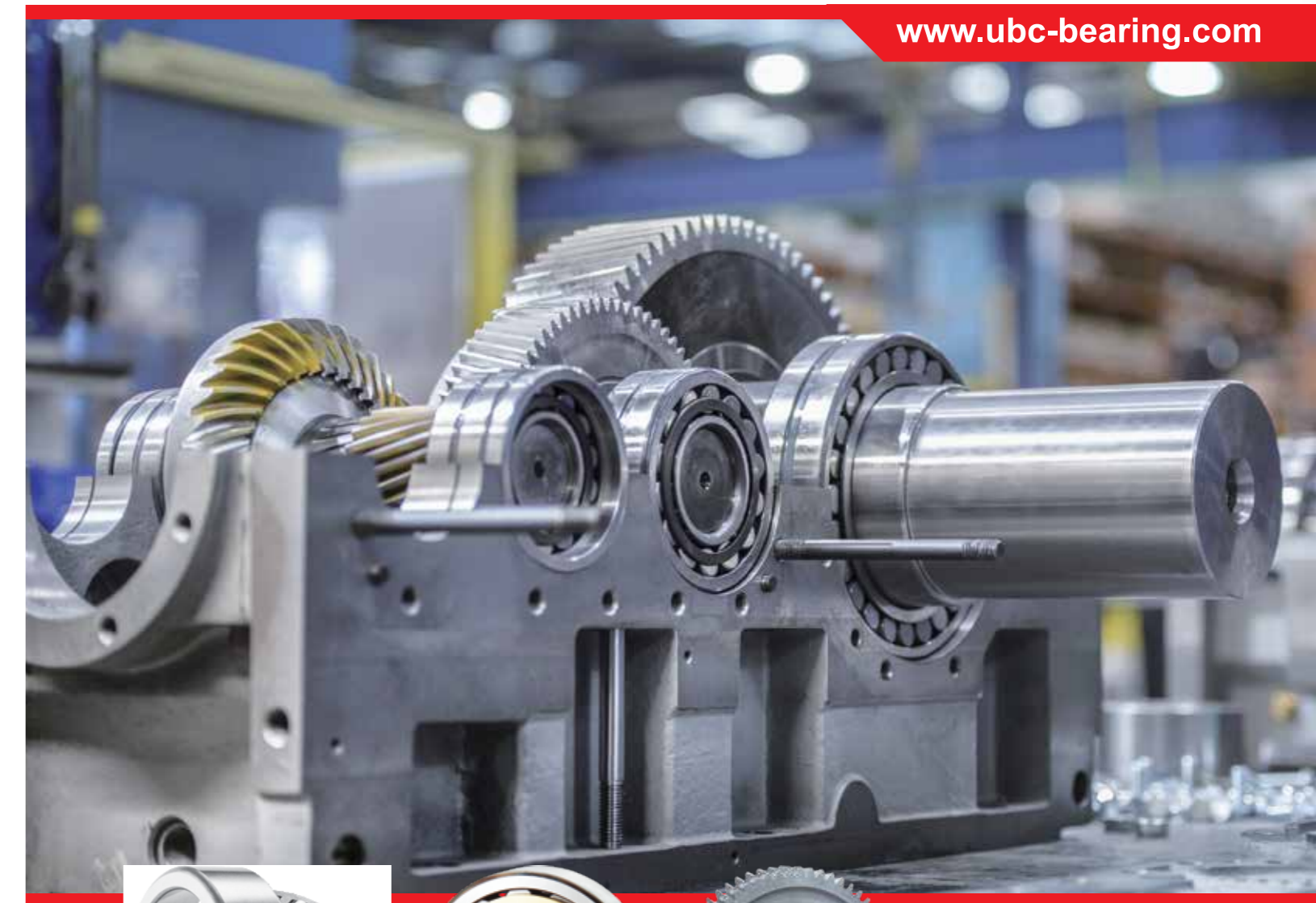

UBC[®]
An **IKO** Company

Our Bearings, Your Solutions



Bearing Solutions for Power Transmission

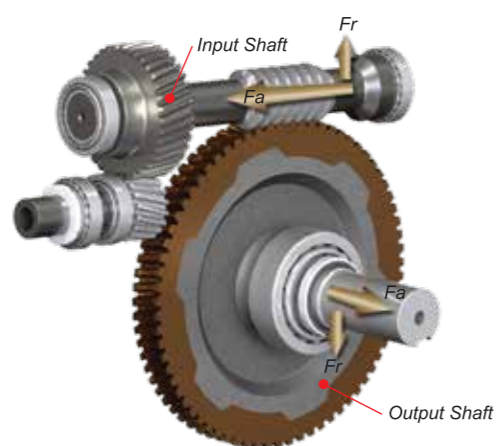

Bearing Solutions In turbo-Worm Reducer

Turbo-worm reducers are configured with a shaft with integrated helical gear as input shaft and a larger worm wheel as output shaft. This kind of reducer features compact structure with high reduction ratio. Due to the angle of helical gear, the turbo-worm reducers have the feature of self-locking, which is widely used in lift and conveyor system.

Discover **UBC**

Input Shaft

The input shaft is subjected to support radial load generated by input torque and high axial load generated by larger worm wheel. In this bearing configuration, two angular contact ball bearings or two tapered roller bearings are the perfect solution with high load capacity and rigidity.

Output Shaft

Bearings on output shaft are usually subjected to carry high radial load generated by the worm shaft, and relative lower axial load induced by the helical gear. This configuration, two deep groove ball bearings are adequate while one cylindrical roller bearing and a spherical roller bearing combination is preferable when the worm wheel is suffering higher loads.



UBC[®]
An **IKO** Company

UBC Precision Bearing Mfg. Co.,Ltd.
Suite 1703, Zhongrong Plaza, 1088 South Pudong Road, Pudong New District, Shanghai
TEL: +86-21-64904536
FAX: +86-21-68781355
Email: export@ubc-bearing.com

China factory and Technology Center
UBC (Suzhou) Bearing Co.,Ltd.
1083 Southeast Avenue, Changshu National New & Hi-tech Industrial Development Zone, Changshu City, Jiangsu Province, China